

PanelView Plus 700 to 1500 and PanelView Plus Compact 1000 Terminals and Display Modules

Catalog Numbers 2711P-Kxxxx, 2711P-Txxxx, 2711P-Bxxxx, 2711P-RDxxxx, 2711PC-T10C4D1

Topic	Page
Important User Information	2
Environment and Enclosure	3
Hazardous Locations	4
Wiring and Safety Guidelines	8
About the PanelView Plus 700 to 1500 Terminals	8
Parts List	10
Required Tools	10
Install the Terminal	10
DC Power Connections	16
AC Power Connections	20
Battery Precautions	22
Troubleshooting	24
Specifications	28
Additional Resources	30

About This Publication

This document provides instructions on how to install these devices in a panel.

- Factory-assembled PanelView Plus or PanelView Plus CE 700 to 1500 terminals
- PanelView Plus or PanelView Plus CE 700 to 1500 display modules
- Factory-assembled PanelView Plus Compact 1000 terminal

For complete information on installing, wiring, and troubleshooting the terminals, refer to the publications listed under Additional Resources.

Important User Information

Solid state equipment has operational characteristics differing from those of electromechanical equipment. Safety Guidelines for the Application, Installation and Maintenance of Solid State Controls (Publication [SGI-1.1](#) available from your local Rockwell Automation sales office or online at <http://literature.rockwellautomation.com>) describes some important differences between solid state equipment and hard-wired electromechanical devices. Because of this difference, and also because of the wide variety of uses for solid state equipment, all persons responsible for applying this equipment must satisfy themselves that each intended application of this equipment is acceptable.





In no event will Rockwell Automation, Inc. be responsible or liable for indirect or consequential damages resulting from the use or application of this equipment.

The examples and diagrams in this manual are included solely for illustrative purposes. Because of the many variables and requirements associated with any particular installation, Rockwell Automation, Inc. cannot assume responsibility or liability for actual use based on the examples and diagrams.

No patent liability is assumed by Rockwell Automation, Inc. with respect to use of information, circuits, equipment, or software described in this manual.

Reproduction of the contents of this manual, in whole or in part, without written permission of Rockwell Automation, Inc., is prohibited.

Throughout this manual, when necessary, we use notes to make you aware of safety considerations.

WARNING 	Identifies information about practices or circumstances that can cause an explosion in a hazardous environment, which may lead to personal injury or death, property damage, or economic loss.
IMPORTANT	Identifies information that is critical for successful application and understanding of the product.
ATTENTION 	Identifies information about practices or circumstances that can lead to personal injury or death, property damage, or economic loss. Attentions help you identify a hazard, avoid a hazard and recognize the consequences.
SHOCK HAZARD 	Labels may be on or inside the equipment (for example, a drive or motor) to alert people that dangerous voltage may be present.
BURN HAZARD 	Labels may be on or inside the equipment (for example, a drive or motor) to alert people that surfaces may reach dangerous temperatures.

Environment and Enclosure

ATTENTION

This equipment is intended for use in a Pollution Degree 2 industrial environment, in overvoltage Category II applications (as defined in IEC publication 60664-1), at altitudes up to 2000 m (6561 ft) without derating.

The terminals are intended for use with programmable logic controllers. Terminals that are AC powered must also be connected to the secondary of an isolating transformer.

This equipment is considered Group 1, Class A industrial equipment according to IEC/CISPR Publication 11. Without appropriate precautions, there may be potential difficulties ensuring electromagnetic compatibility in other environments due to conducted as well as radiated disturbance.

Korean Radio Wave Suitability Registration - This equipment is registered for Electromagnetic Conformity Registration as business equipment (A), not home equipment. Sellers or users are required to take caution in this regard.

This equipment is supplied as open-type equipment. It must be mounted within an enclosure that is suitably designed for those specific environmental conditions that will be present and appropriately designed to prevent personal injury resulting from accessibility to live parts. The interior of the enclosure must be accessible only by the use of a tool. The terminals meet specified NEMA Type and IEC ratings only when mounted in a panel or enclosure with the equivalent rating. Subsequent sections of this publication may contain additional information regarding specific enclosure type ratings that are required to comply with certain product safety certifications.

In addition to this publication, see:

- Industrial Automation Wiring and Grounding Guidelines, for additional installation requirements, publication [1770-4.1](#).
- NEMA Standards publication 250 and IEC publication 60529, as applicable, for explanations of the degrees of protection provided by different types of enclosure.

ControlNet Communication Port

ATTENTION

PanelView Plus terminals with ControlNet communications ports include a Network Applications Port (NAP). This port is for temporarily connecting programming terminals to devices on a ControlNet network, and are not intended for continuous operation.

Hazardous Locations

This equipment is suitable for these locations:

- Class I, Division 2 Groups A, B, C, D
- Class II, Division 2 Groups F, G
- Class III
- Ordinary, nonhazardous locations only

The following statement applies to use in hazardous locations.

WARNING



Explosion Hazard

- Substitution of components may impair suitability for hazardous locations.
 - Do not disconnect equipment unless power has been switched off and area is known to be nonhazardous.
 - Do not connect or disconnect components unless power has been switched off.
 - All wiring must comply with N.E.C. articles 501, 502, 503, and/or C.E.C. section 18-1J2 as appropriate.
 - Peripheral equipment must be suitable for the location in which it is used.
-

The terminals have a temperature code of T4 when operating in a 55 °C (131 °F) maximum ambient temperature. Do not install the terminals in environments where atmospheric gases have ignition temperatures **less** than 135 °C (275 °F).

Environnements dangereux

Cet équipement ne peut être utilisé que dans les environnements suivants :

- Classe I, Division 2, Groupes A, B, C, D
- Classe II, Division 2, Groupes F, G
- Classe III
- ou environnements non-dangereux

La mise en garde suivante s'applique à une utilisation en environnement dangereux.

AVERTISSEMENT



DANGER D'EXPLOSION

- La substitution de composants peut rendre cet équipement impropre à une utilisation en environnement dangereux.
- Ne pas déconnecter l'équipement sans s'être assuré que l'alimentation est coupée ou que l'environnement est classé non dangereux.
- Ne pas connecter ou déconnecter des composants sans s'être assuré que l'alimentation est coupée.
- L'ensemble du câblage doit être conforme, selon le cas, aux articles 501-4(b), 502-4(b) et 503-3(b) du Code national de l'électricité des Etats-Unis.
- L'équipement périphérique doit être adapté à l'environnement dans lequel il est utilisé.

Le code de température de fonctionnement des terminaux PanelView Plus et PanelView Plus CE est T4 pour une température ambiante maximale de 55 °C. N'installez pas les terminaux dans des environnements contenant des gaz atmosphériques inflammables à moins de 135 °C.

USB Ports

All PanelView Plus and PanelView Plus Compact terminals contain universal serial bus (USB) ports that comply with hazardous location environments. This section details the field-wiring compliance requirements and is provided in accordance with the National Electrical Code, article 500.

Terminals Control Drawing

Associated Nonincendive Field Wiring Apparatus

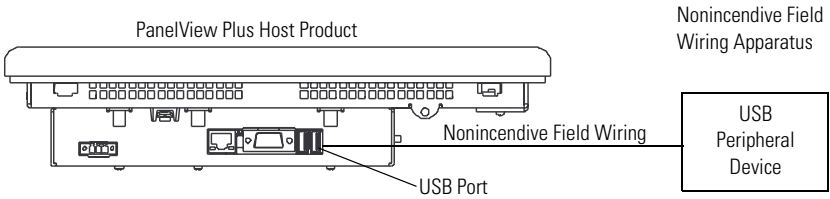

Table 1 - PanelView Plus USB Port Circuit Parameters

V_{oc}	I_{sc}	C_a		L_a	
		Groups A and B	Groups C and D	Groups A and B	Groups C and D
5.25V DC	1.68 A	10 μ F	10 μ F	15 μ H	15 μ H

Selected nonincendive field wiring apparatus must have nonincendive circuit parameters conforming with Table 2.

Table 2 - Required Circuit Parameters for the USB Peripheral Device

V_{max}	\geq	V_{oc}
I_{max}	\geq	I_{sc}
$C_i + C_{cable}$	\leq	C_a
$L_i + L_{cable}$	\leq	L_a

Application Information

Per the National Electrical Code the circuit parameters of nonincendive field wiring apparatus for use in hazardous locations shall be coordinated with the associated nonincendive field wiring apparatus such that their combination remains nonincendive. The PanelView Plus terminals and the USB peripheral device shall be treated in this manner.

The circuit parameters of the PanelView Plus USB port are given in Table 1. The USB peripheral device and its associated cabling shall have circuit parameters with the limits given in Table 2 for them to remain nonincendive when used with the PanelView Plus USB port. If cable capacitance and inductance are not known the following values from ANSI/ISA-RP 12.06.01-2003 may be used:

$$C_{\text{cable}} = 197 \mu\text{F}/\text{m} \text{ (} 60 \mu\text{F}/\text{ft}\text{)}$$

$$L_{\text{cable}} = 0.7 \mu\text{H}/\text{m} \text{ (} 0.20 \mu\text{H}/\text{ft}\text{)}$$

Nonincendive field wiring must be wired and separated in accordance with 501.10(B)(3) of the National Electrical Code (NEC) ANSI/NFPA 70 or other local codes as applicable.

This associated nonincendive field wiring apparatus has not been evaluated for use in combination with another associated nonincendive field wiring apparatus.

Symbol Definitions

V_{oc}	Open circuit voltage of the host USB port.
I_{sc}	Maximum output current of the host USB port.
V_{max}	Maximum applied voltage rating of the USB peripheral device. V_{max} shall be greater than or equal to V_{oc} in Table 1 ($V_{\text{max}} \geq V_{\text{oc}}$).
I_{max}	Maximum current to which the USB peripheral device can be subjected. I_{max} shall be greater than or equal to I_{sc} in Table 1 ($I_{\text{max}} \geq I_{\text{sc}}$).
C_i	Maximum internal capacitance of the USB peripheral device.
C_a	Maximum allowed capacitance of the USB peripheral device and its associated cable. The sum of C_i of the USB peripheral device and C_{cable} of the associated cable shall be less than or equal to C_a ($C_i + C_{\text{cable}} \leq C_a$).
L_i	Maximum internal inductance of the USB peripheral device.
L_a	Maximum allowed inductance of the USB peripheral device and its associated cable. The sum of L_i of the USB peripheral device and L_{cable} of the associated cable shall be less than or equal to L_a ($L_i + L_{\text{cable}} \leq L_a$).

Wiring and Safety Guidelines

Use publication NFPA 70E, Electrical Safety Requirements for Employee Workplaces, IEC 60364 Electrical Installations in Buildings, or other applicable wiring safety requirements for the country of installation when wiring the devices. In addition to the NFPA guidelines:

- connect the device and other similar electronic equipment to its own branch circuit.
- protect the input power by a fuse or circuit breaker rated at no more than 15 A.
- route incoming power to the device by a separate path from the communication lines.
- cross power and communication lines at right angles if they must cross.
Communication lines can be installed in the same conduit as low-level DC I/O lines (less than 10V).
- shield and ground cables appropriately to avoid electromagnetic interference (EMI).
Grounding minimizes noise from EMI and is a safety measure in electrical installations.

For more information on grounding recommendations, refer to the National Electrical Code published by the National Fire Protection Association.

For more information, refer to Wiring and Grounding Guidelines for PanelView Plus/PanelView Plus CE Devices Technical Data, publication [2711P-TD001](#). You can find this publication in the Literature Library website, <http://literature.rockwellautomation.com>.

About the PanelView Plus 700 to 1500 Terminals

The PanelView Plus terminals have these modular components:

- Display module (700, 1000, 1250, and 1500)
- Logic module with AC or DC power, CompactFlash card slot, Ethernet port, serial port, and USB ports
- Internal CompactFlash card with firmware or operating system, RAM memory (SO-DIMM)
- Communication module for specific communication protocols

These items can be ordered as separate components for field installation or factory assembled per your configuration. The base-configured unit includes the display module and the logic module with internal CompactFlash and RAM.

Modular Components

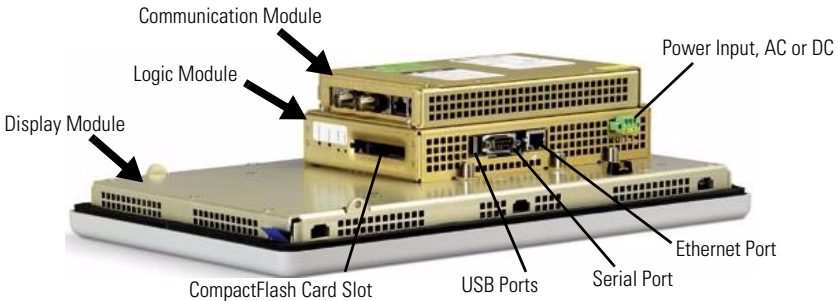

If the modules are ordered separately, attach the logic and communication module to the display module before panel installation. See the instructions shipped with each module.

The logic module for the terminals is available with or without RAM and CompactFlash preinstalled. If memory is ordered separately, you must install the memory before attaching the logic module to the display module. See the instructions shipped with the logic module.

About the PanelView Plus Compact 1000 Terminal

The PanelView Plus Compact 1000 terminal has a fixed configuration. It does not support communication modules, or the replacement of the logic module. The 1000 terminal contains a non-isolated DC power supply.

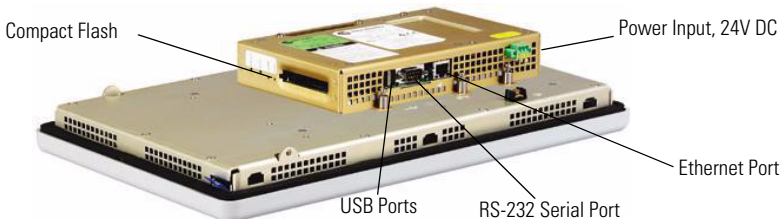

The PanelView Plus Compact 1000 terminal has these features:

- 1000 touch screen display module
- USB ports (2)
- RS-232 serial port
- 10/100Base T Ethernet port
- Power input, 24V DC non-isolated
- CompactFlash Type 1 card slot

Parts List

These items are shipped with the terminals:

- Power terminal block
- Mounting clips
- FactoryTalk View software preloaded
- Installation instructions and panel cutout template

Required Tools

These tools are required for panel installation:

- Panel cutout tools
- Small, slotted screwdriver
- Torque wrench (lb•in)

Install the Terminal

Before installing the terminal in a panel, review the following topics:

- Mounting clearances
- Panel cutout dimensions
- Product dimensions

Mounting Clearances

Allow adequate clearance around the terminal, inside the enclosure, for adequate ventilation. Consider heat produced by other devices in the enclosure. The ambient temperature around the terminals must be between 0...55 °C (32...131 °F).

These minimum clearances are required for ventilation.

- Top clearance: 51 mm (2 in.)
- Bottom clearance: 102 mm (4 in.)
- Side clearances: 25 mm (1 in.)
- Back clearance: 25 mm (1 in.)

Minimum side clearance for insertion of memory card is 102 mm (4 in.).

Panel Cutout Dimensions

Use the full size template shipped with your terminal to mark the cutout dimensions.

Terminal Type	Height, mm (in.)	Width, mm (in.)
700 Keypad or Keypad and Touch	167 (6.57)	264 (10.39)
700 Touch	154 (6.08)	220 (8.67)
1000 Keypad or Keypad and Touch	224 (8.8)	375 (14.75)
1000 Touch	224 (8.8)	305 (12.00)
1250 Keypad or Keypad and Touch	257 (10.11)	390 (15.35)
1250 Touch	257 (10.11)	338 (13.29)
1500 Keypad or Keypad and Touch	305 (12.00)	419 (16.50)
1500 Touch	305 (12.00)	391 (15.40)

Mount the Terminal in a Panel

Mounting clips secure the terminal to the panel. The number of clips you use (4, 6, or 8) varies by terminal type.

ATTENTION



Disconnect all electrical power from the panel before making the panel cutout.

Make sure the area around the panel cutout is clear.

Take precautions so metal cuttings do not enter any components already installed in the panel.

Failure to follow these instructions may result in personal injury or damage to panel components.

Follow these steps to mount the terminal in a panel.

1. Cut an opening in the panel by using the panel cutout shipped with the terminal.
2. Make sure the terminal sealing gasket is properly positioned on the terminal.

This gasket forms a compression type seal. Do not use sealing compounds.

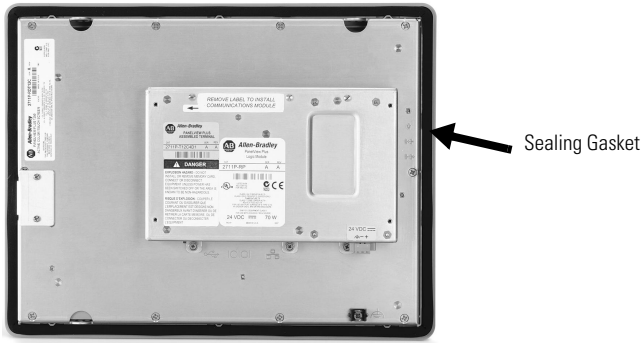

3. Install the legend strips before installing the terminal if you are using keypad legend strips on keypad terminals.
Be careful not to pinch the legend strip during installation.
4. Place the terminal in the panel cutout.
5. Slide the ends of the mounting clips into the slots on the terminal.

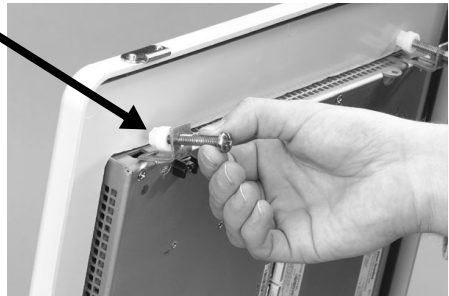
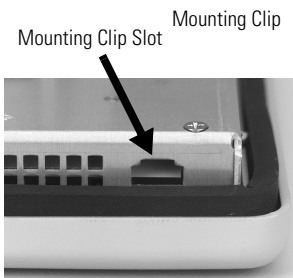

6. Tighten the mounting clip screws by hand until the gasket seal contacts the mounting surface uniformly.



- Tighten the mounting clip screws to a torque of 0.90...1.1 N•m (8...10 lb•in) by using the specified torque sequence, making sure not to overtighten.

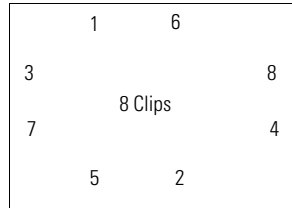
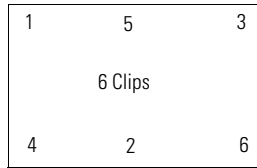
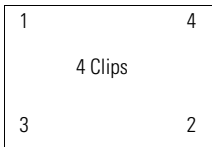

ATTENTION



Tighten the mounting clips to the specified torque to provide a proper seal and prevent damage to the product. Rockwell Automation assumes no responsibility for water or chemical damage to the product or other equipment within the enclosure because of improper installation.

Product Dimensions

The table provides product dimensions for the terminals including depth dimensions for the:

- base configured unit (display module and logic module).
- base configured unit with communication module.

Terminal Type	Height, Approx., mm (in.)	Width, Approx., mm (in.)	Depth, Approx., mm (in.)
700 Keypad or Keypad and Touch	193 (7.58)	290 (11.40)	55 (2.18)
700 Touch Screen	179 (7.04)	246 (9.68)	display to logic module 83 (3.27)
1000 Keypad or Keypad and Touch	248 (9.77)	399 (15.72)	display to comm module
1000 Touch Screen	248 (9.77)	329 (12.97)	
1250 Keypad or Keypad and Touch	282 (11.12)	416 (16.36)	
1250 Touch Screen	282 (11.12)	363 (14.30)	
1500 Keypad or Keypad and Touch	330 (12.97)	469 (18.46)	65 (2.55)
1500 Touch Screen	330 (12.97)	416 (16.36)	display to logic module 93 (3.65) display to comm module

The illustration shows product dimensions for the PanelView Plus and PanelView Plus Compact 1000 touch only terminals. The other size terminals look similar. Measurements are in mm (in.).

1000 Terminal Dimensions

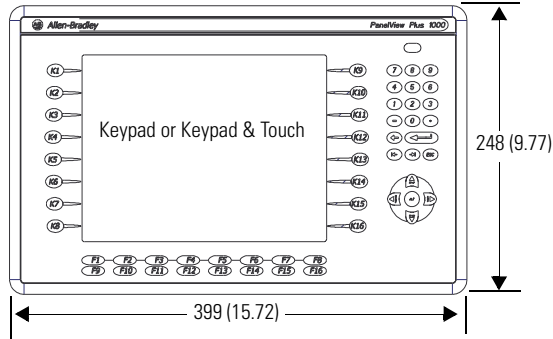

- a 55 (2.18) Display to Logic Module
- b 83 (3.27) Display to Comm Module

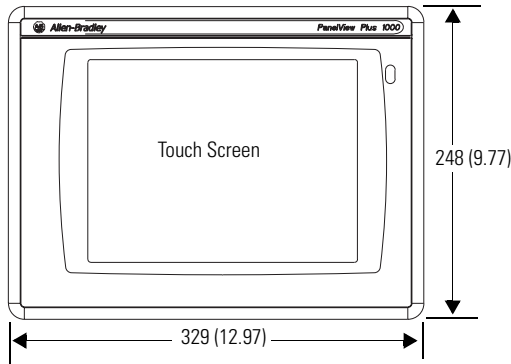
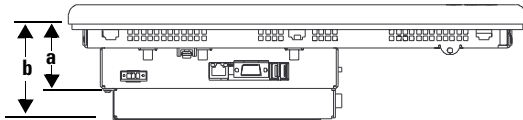

- a 55 (2.18) Display to Logic Module
- b 83 (3.27) Display to Comm Module

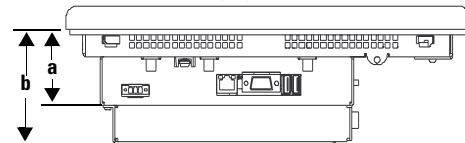

Ethernet Wiring

Use Belden 7921A shielded Ethernet Category 5e cable according to TIA 568-B.1 and RJ45 connector according to IEC 60603-7 for compliance with Marine emissions limits and European Union 89/336/EEC EMC Directive.

The maximum cable length between the terminal's Ethernet port and a 10/100 Base-T port on an Ethernet hub (without repeaters or fiber) is 100 m (328 ft).

Remove and Install the Power Terminal Block

The terminals are shipped with a power terminal block installed. You can remove the terminal block for ease of installation, wiring, and maintenance.

WARNING



Explosion Hazard

Substitution of components may impair suitability for hazardous locations.

Do not disconnect equipment unless power has been switched off and area is known to be nonhazardous.

Do not connect or disconnect components unless power has been switched off.

All wiring must comply with N.E.C. articles 501, 502, 503, and/or C.E.C. section 18-1J2 as appropriate.

Peripheral equipment must be suitable for the location in which it is used.

ATTENTION



Disconnect all power before installing or replacing components. Failure to disconnect power may result in electrical shock or damage to the terminal.

- Series A to D, DC logic modules use a 3-position terminal block.
- Series E or later, DC logic modules use a 2-position terminal block.
- All logic modules with an AC power input use a 3-position terminal block.

Follow these steps to remove the terminal block.

1. Loosen the two screws that secure the terminal block.
2. Gently pull the terminal block away from the connector.

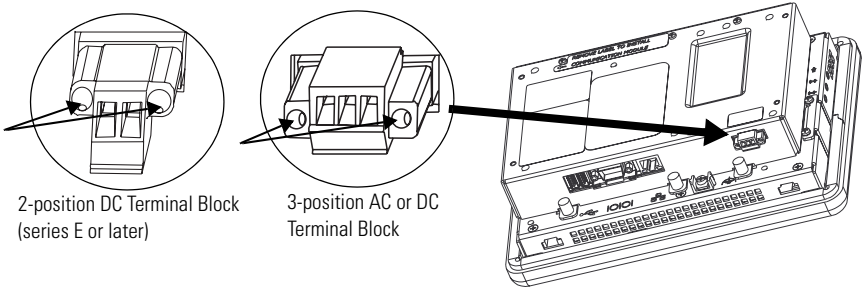

2-position DC Terminal Block (series E or later)

3-position AC or DC Terminal Block

Follow these steps to install the terminal block.

1. Reattach the terminal block to the connector until seated.
2. Tighten the two screws that secure the terminal block to the connector.

DC Power Connections

DC-powered PanelView Plus devices have an integrated 24V DC power supply. Both isolated and non-isolated power supplies have these ratings:

- 24V DC nominal (18...32V DC)
- 70 W maximum (2.9 A at 24V DC)

The power supply is internally protected against reverse polarity of the DC+ and DC- connections. Connecting DC+ or DC- to the earth/ground terminal may damage the device.

The input power terminal block supports these wire sizes.

Wire Specifications for DC Input Power Terminal Block

Logic Module	Wire Type		Dual-wire Gauge ⁽¹⁾	Single-wire Gauge	Terminal Screw Torque
Series A to D	Stranded or solid	Cu 90 °C (194 °F)	22...16 AWG	22...14 AWG	0.23...0.34 N•m (2...3 lb•in)
Series E and later					0.56 N•m (5 lb•in)

⁽¹⁾ Two-wire max per terminal.

External Power Supply For Non-isolated DC Terminals

TIP

To identify non-isolated DC logic modules refer to the PanelView Plus Terminals user manual, publication [2711P-UM001](#).

Use a single, 24V DC power supply to power each PanelView Plus device, such as catalog number 2711P-RSACDIN. Using a separate, isolated and ungrounded source to power each terminal prevents ground loop currents from damaging the terminals.

The output on the power supply must be isolated from the input and not connected to earth/ground.

ATTENTION



Use a Class 2 or SELV supply as required by local wiring codes for your installation. The Class 2 and SELV power sources provide protection so that under normal and single-fault conditions, the voltage between the conductors, and between the conductors and functional earth or protective earth does not exceed a safe value.

Multiple AC Power Supplies to Power Multiple DC Terminals

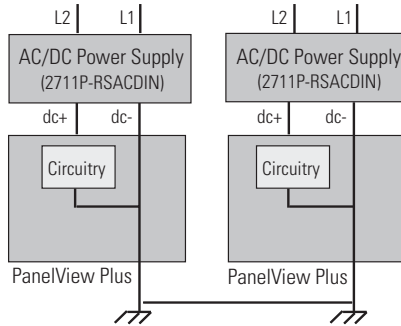

External Power for Isolated DC Terminals

TIP

Isolated DC logic modules are identified by catalog number 2711P-RPx Dx.

Use an SELV or PELV 24V DC power supply, such as catalog number 2711P-RSACDIN, to power the isolated DC PanelView Plus terminal.

The isolated DC terminals may be powered by the same power source as other equipment.

ATTENTION



Use an SELV or PELV supply as required by local wiring codes for your installation. The SELV and PELV power sources provide protection so that under normal and single fault conditions, the voltage between conductors and earth ground does not exceed a safe value.

Earth/Ground Connection

PanelView Plus devices with a DC power input have a earth/ground terminal that you must connect to a low-impedance earth/ground. The earth/ground connection is on the rear of the display module.

IMPORTANT

The earth/ground connection to ground is mandatory. This connection is required for noise immunity, reliability, and Electromagnetic Compliance (EMC) with the European Union (EU) EMC directive for CE-mark conformance. This connection is required for safety by Underwriters Laboratory.

The earth/ground terminal requires a minimum wire gauge.

Earth/Ground Wire Specifications for DC Power

Symbol	Wire Type	Wire Gauge	Terminal Screw Torque
 GND	Stranded or solid Cu 90 °C (194 °F)	14...10 AWG	1.13...1.36 N•m (10...12 lb•in)

On most PanelView Plus devices, the earth/ground terminal is internally connected to the DC- terminal within the product.

ATTENTION



Damage or malfunction can occur when a voltage potential exists between two separate ground points. Make sure the terminal does not serve as a conductive path between ground points at different potentials.

The PanelView Plus devices have isolated and non-isolated communication ports. For more information refer to the PanelView Plus Terminals User Manual, publication [2711P-UM001](#).

Connect DC Power

WARNING



Explosion Hazard - Do not disconnect equipment unless power has been switched off and area is known to be nonhazardous.

Disconnect all power before installing or replacing components. Failure to disconnect power may result in electrical shock or damage to the terminal.

Follow these steps to connect the terminal DC power.

1. Verify that the terminal is not connected to a power source.
2. Secure the DC power wires to the terminal block.
Follow the markings on the terminal blocks and the terminal for proper connections.
3. Secure the earth/ground wire to the earth/ground terminal screw at the bottom of the display.

DC Power Supply Connections

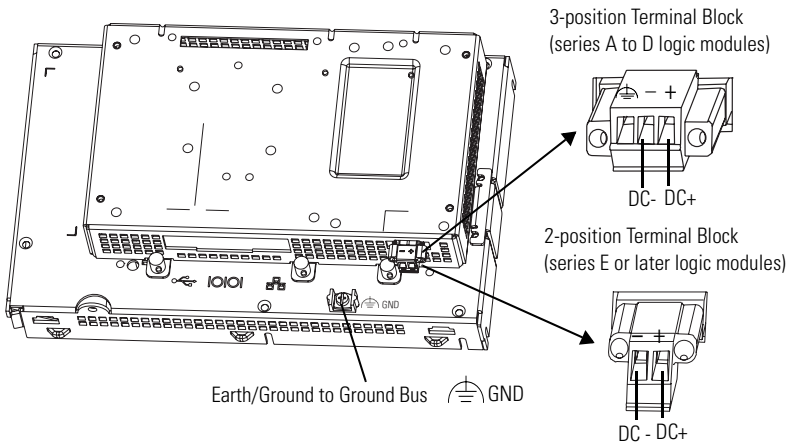

AC Power Connections

PanelView Plus devices with an integrated AC power supply have these power ratings:

- 85...264V AC (47...63 Hz)
- 160V A max

The input power terminal block supports these wire sizes.

Wire Specifications for AC Input Power Terminal Block

Wire Type		Dual-wire Gauge ⁽¹⁾	Single-wire Gauge	Terminal Screw Torque
Stranded or solid	Cu 90 °C (194 °F)	22...16 AWG	22...14 AWG	0.56 N•m (5 lb•in)

⁽¹⁾ Two-wire max. per terminal.

Protective Earth and Functional Earth Connection

PanelView Plus devices with an AC power input have both a protective earth and functional earth terminal that you must connect to a low-impedance earth ground.

- Protective earth terminal is on the power input terminal block.
- Functional earth connection is on the back of the display.

ATTENTION



The functional earth and protective earth connections to ground are mandatory. The functional earth ground connection is required for electromagnetic compliance (EMC) with the EU (European Union) EMC directive for CE-mark conformance. The protective earth ground connection is required for safety and regulatory compliance.

IMPORTANT

On PanelView Plus devices with an AC power input, you must connect both protective earth and functional earth to ground.

The protective earth and functional earth terminals require a minimum wire gauge.

Functional Earth and Protective Earth Wire Specifications for AC Power

Connection		Wire Type		Wire Gauge	Terminal Screw Torque
Protective earth		Stranded or solid	Cu 90 °C (194 °F)	14...12 AWG	0.56 N•m (5 lb•in)
Functional earth		Stranded or solid	Cu 90 °C (194 °F)	14...10 AWG	1.13...1.36 N•m (10...12 lb•in)

Connect AC Power

WARNING



Explosion Hazard - Do not connect or disconnect equipment while circuit is live unless area is known to be nonhazardous.

Disconnect all power before installing or replacing components. Failure to disconnect power may result in electrical shock and/or damage to the terminal.

ATTENTION



Improper wiring of power terminals may result in voltage at the communication connector shells. Refer to the following figure when wiring.

Do not apply power to the terminal until all wiring connections have been made. Failure to do so may result in electrical shock.

Follow these steps to connect the terminal to AC power.

1. Verify that the terminal is not connected to a power source.
2. Secure the AC power wires to the terminal block.

Follow the markings on terminal blocks and terminal for proper connections.

3. Secure the protective earth ground wire to the marked position of the power input terminal block.
4. Secure the functional earth ground wire to the functional earth ground screw on the back of the display bus.

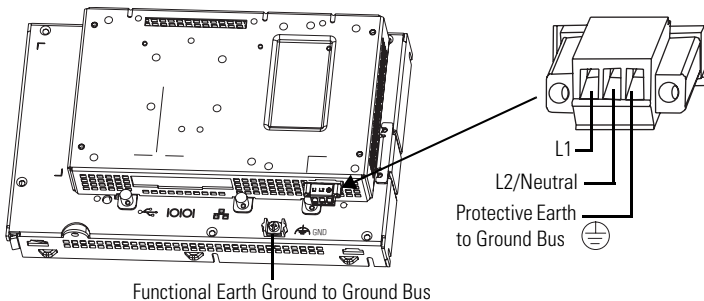

5. Apply AC power to the terminal.

Battery Precautions

WARNING



When you connect or disconnect the battery an electrical arc can occur. This could cause an explosion in hazardous location installations. Be sure that power is removed and the area is nonhazardous before proceeding.

For safety information on the handling of lithium batteries, including handling and disposal of leaking batteries, see [Guidelines for Handling Lithium Batteries](#), publication [AG 5-4](#). Replace the battery only with the indicated catalog number.

Do not dispose of battery in a fire or incinerator. Dispose of used batteries in accordance with local regulations.

Store batteries in a cool, dry environment. We recommend 25 °C (77 °F) with 40...60% relative humidity. You may store batteries for up to 30 days between -45...85 °C (-49...185 °F), such as during transportation. To avoid possible leakage, do not store batteries above 60 °C (140 °F) for more than 30 days.

Replace the Battery

Follow these steps to replace the lithium battery in the logic module of PanelView Plus or PanelView Plus Compact terminals.

1. Disconnect power from the terminal.
2. Place the terminal, display side down, on a flat stable surface.
3. Detach the communication module, if attached, from the logic module by removing the four screws.
4. Loosen the six captive screws that attach the logic module to the display module.

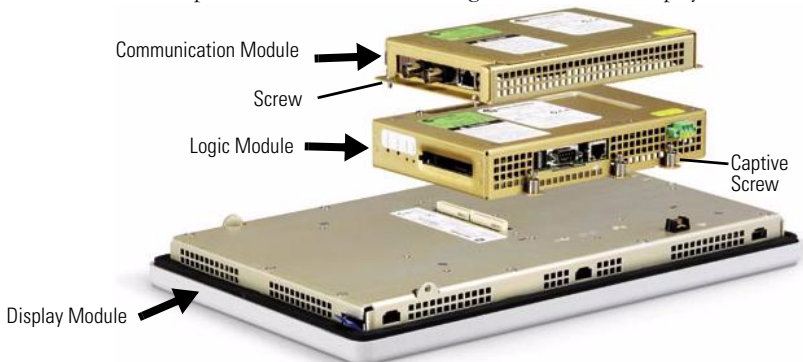

5. Carefully lift the logic module away from the terminal and turn over to expose the circuit board.

6. Locate the battery on the circuit board.

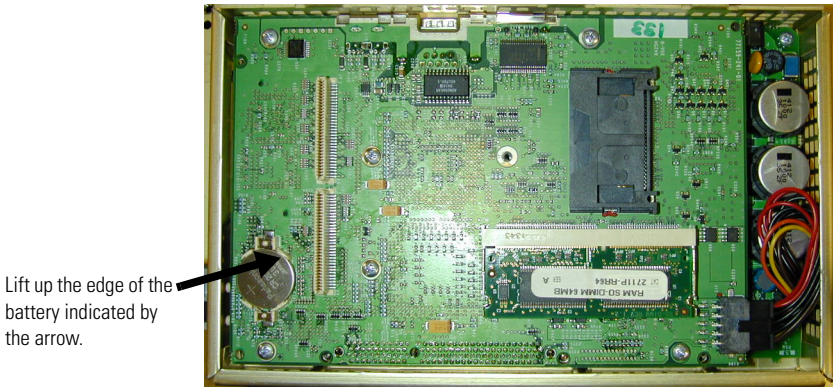

Lift up the edge of the battery indicated by the arrow.

7. Remove the battery by lifting up the side of the battery.
8. Insert the new battery.

IMPORTANT

Use only replacement battery catalog number 2711P-RY2032.

9. Reattach the logic module by aligning the two connectors on the bottom of the module with the connectors on the terminal.



10. Push down on the logic module until it is firmly seated.
11. Tighten the six captive screws that secure the logic module to a torque of 0.58 N•m (5...7 lb•in).

12. Reattach the communication module, if necessary, and tighten the four screws to a torque of 0.58 N•m (5...7 lb•in).



This product contains a hermetically sealed lithium battery which may need to be replaced during the life of the product.

At the end of its life, the battery contained in this product should be collected separately from any unsorted municipal waste.

The collection and recycling of batteries helps protect the environment and contributes to the conservation of natural resources as valuable materials are recovered.

Troubleshooting

If the terminal is not operating correctly, check the power, display settings, status indicators, and review the system startup and error messages.

Check for Adequate Power

A terminal that does not receive adequate power could cause unpredictable behavior. Verify the power requirements in the Specifications table.

Check Status Indicators

The terminal has two status indicators to isolate operating problems.

- COMM indicator (green) for communication
- FAULT indicator (red) for hardware faults

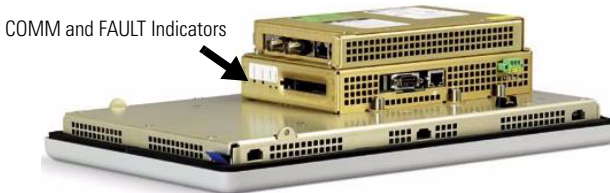

When the terminal starts, the fault indicator should be off, except for a few brief flashes, and the comm indicator on. If the indicators remain off, the power supply or logic module has failed. Check the power cable. If the power is not within range, replace the power supply. If the power is within range, replace the logic module. After a successful startup, both indicators are off and controlled by the application running on the terminal.

The table shows indicator states if the terminal powers on and stops during startup.

Indicator States If the Terminal Stops During Startup

Fault (Red) Indicator	Comm (Green) Indicator	Description
Blinking ⁽¹⁾	Off	Last firmware download failed. Reload firmware using Firmware Upgrade Wizard (FUW) utility.
	Blinking	EBC boot loader firmware failed or is missing. Reload firmware using Firmware Upgrade Wizard (FUW) utility.
	On	Windows CE OS firmware failed or is missing. Reload firmware using Firmware Upgrade Wizard (FUW) utility.
On ⁽²⁾	Off	Fatal hardware error occurred. Replace the logic module.
	Blinking	Fatal hardware error in display. Replace the display module.

⁽¹⁾ Blinking red indicates a recoverable error.

⁽²⁾ Solid red indicates a nonrecoverable or fatal error.

Check the Display

If the terminal display is dim or unreadable:

- check the brightness setting of the display. From Configuration mode on the terminal, access Terminal Settings>Display Intensity.
- check the Screen Saver settings. The backlight may be turning off or dimming the display unexpectedly. From Configuration mode on the terminal, access Terminal Settings>Display>Screen Saver.

Startup Information Messages

Startup information messages display in a specific sequence on the terminal during startup and typically display for a few seconds. These messages do not require that you perform any action.

Message #	Message	Description
37	Video Initialized	Configures and initializes the graphics video system.
30	Watchdog Test	Tests the watchdog circuitry to verify system integrity.
1	RAM Test	Tests the RAM memory.
31	Stuck Key	Checks the integrity of the function key hardware.
31.5	Stuck Touch	Checks the integrity of the touch screen hardware.
32	Battery Test	Checks the integrity of the battery hardware.
2.5	Registry Search	Locates and loads the most recent, valid registry. Multiple copies of the registry are maintained. If power is lost during a registry update, a valid registry is available the next time power is applied to the terminal.
2	Image Search	Checks for a new OS firmware upgrade on the external CompactFlash card and the serial port.
50	External CF	Transfers a new OS firmware upgrade from the external CompactFlash card to the terminal. Message may display for several minutes.
23	Internal CF	Programs the OS firmware just downloaded into the internal flash memory. Message may display for several minutes.
24	CRC Check	Checks the integrity of the OS firmware.
28	Starting System	Launches the operating system (OS).
29	System Check ###	Internal file system integrity check (### is percent progress indicator).
29.1	System Check	Internal file system integrity check disabled. Contact technical support.

Startup Error Messages

When an error occurs, the terminal displays an error number with a text message. The word ERROR! appears under the message in different languages.

Displayed Message
ERROR! FEHLER! ERREUR! ERRORE!

Error #	Message	Description	Recommended Corrective Action
1	RAM Test	RAM test failure.	Reset the terminal. If error persists, reseal the SO-DIMM RAM module. If error still persists, replace the logic module.
23	Internal CF	Error programming the new OS firmware to internal CompactFlash card.	Reload the firmware. If error persists, replace the internal CompactFlash card. If error still persists, replace the logic module.
24	CRC Check	Checksum of the OS firmware failed.	Reload the firmware. If error persists, replace the internal CompactFlash card. If error still persists, replace the logic module.
30	Watchdog Test	Watchdog test failure.	Reload the firmware. If error persists, replace the logic module.
31	Stuck Key	Function key failure.	Check that nothing is pressed against a key. Reset the terminal without key presses. If error persists, replace the display module.
31.5	Stuck Touch	Touch screen failure.	Check that nothing is pressed against the touch screen. Reset the terminal without pressing the touch screen. If error persists, replace the display module.
32	Battery Test	Battery failure.	Replace the battery. If error persists, replace the logic module.
33.5	NVRAM Access	Nonvolatile memory failure.	Upgrade the system firmware to revision 3.10.03 or later.
40	EXE Check	System OS firmware is missing or corrupt.	Reload the firmware. If error persists, replace the internal CompactFlash card. If error still persists, replace the logic module.
50	External CF	Error loading the OS firmware from the external CompactFlash card.	Reload the firmware. If error persists, replace the external CompactFlash card and attempt the firmware upgrade again.

Specifications

PanelView Plus Terminals - 2711P-Kxxxx, 2711P-Txxxx, 2711P-Bxxxx, 2711P-RDxxxx, 2711PC-Txxxx

Attribute	Value
Display	
Display type	Color active matrix, thin film transistor (TFT), liquid crystal display (LCD)
Display size	
700	6.5 in.
1000	10.4 in.
1250	12.1 in.
1500	15 in.
Display area (WxH)	
700	132 x 99 mm (5.2 x 3.9 in.)
1000	211 x 158 mm (8.3 x 6.2 in.)
1250	246 x 184 mm (9.7 in x 7.2 in.)
1500	304 x 228 mm (12.0 x 9.0 in.)
Display resolution	
700	640 x 480
1000	640 x 480
1250	800 x 600
1500	1024 x 768
Luminance	300 cd/m ² Nits
Touch screen	Analog resistive
Electrical	
Input voltage, DC	24V DC nom (18... 32V DC)
Power consumption, DC	70 W max (2.9 A @ 24V DC) 39 W typical (1.6 A @ 24V DC)
Input voltage, AC	85... 264V AC (47... 63 Hz)
Power consumption, AC	160 VA max (65 VA typical)
PCI slot max. available power ⁽¹⁾	
Supply, DC	11 W
Supply, AC	5 W
Dimensions, Approx., (HxWxD) for based configured unit without communication module	
700 keypad, or keypad and touch	193 x 290 x 55 mm (7.58 x 11.40 x 2.18 in.)
700 touch	179 x 246 x 55 mm (7.04 x 9.68 x 2.18 in.)
1000 keypad, or keypad and touch	248 x 399 x 55 mm (9.77 x 15.72 x 2.18 in.)
1000 touch	248 x 329 x 55 mm (9.77 x 12.97 x 2.18 in.)
1250 keypad, or keypad and touch	282 x 416 x 55 mm (11.12 x 16.36 x 2.18 in.)
1250 touch	282 x 363 x 55 mm (11.12 x 14.30 x 2.18 in.)
1500 keypad, or keypad and touch	330 x 469 x 65 mm (12.97 x 18.46 x 2.55 in.)
1500 touch	330 x 416 x 65 mm ((12.97 x 16.37 x 2.55 in.)

⁽¹⁾ The PCI slot does not apply to the PanelView Plus Compact 1000 terminal.

PanelView Plus Terminals - 2711P-Kxxxx, 2711P-Txxxx, 2711P-Bxxxx, 2711P-RDxxxx, 2711PC-Txxxx

Weight, Approx. for base configured unit without communication module	
700 keypad, or keypad and touch	1.9 kg (4.2 lb)
700 touch	1.7 kg (3.8 lb)
1000 keypad, or keypad and touch	2.9 kg (6.3 lb)
1000 touch	2.6 kg (5.7 lb)
1250 keypad, or keypad and touch	3.4 kg (7.6 lb)
1250 touch	3.2 kg (7.1 lb)
1500 keypad, or keypad and touch	4.6 kg (10.0 lb)
1500 touch	4.2 kg (9.3 lb)
General	
Battery life	4 years min. at 25 °C (77 °F)
Clock	Battery-backed, +/- 2 minutes per month
Status indicators	COMM (green), Fault (red)
Application flash memory	
700 to 1500 series D or earlier logic modules	
2711P-RW1	26 MB
2711P-RW2	72 MB
2711P-RW3	95 MB
700 to 1500 series E or later logic modules	
2711P-RW6	80 MB
2711P-RW7	203 MB
2711P-RW8	446 MB
External CompactFlash storage	512 MB max

Environmental Specifications

Specification	Value
Temperature, operating	0...55 °C (32...131 °F)
Temperature, nonoperating	-20...70 °C (-13...158 °F)
Vibration	10...57 Hz, 0.012 pk-pk displacement 57...500 Hz 2.0 g pk acceleration
Shock, operating	15 g at 11 ms
Shock, nonoperating	30 g at 11 ms
Relative humidity	5...95% without condensation
Enclosure ratings	NEMA Type 12, 13, 4X (indoor use only), IP54, IP65
Airborne Contaminants	ANSI/ISA S71.04-1985 Severity Level G3 EN60654-4:1998 Class 3

Certifications

Certification ⁽¹⁾	
c-UL-us	UL Listed Industrial Control Equipment, certified for use in US and Canada. See File E10314. UL Listed Industrial Control Equipment for use in: <ul style="list-style-type: none"> • Class I, Div 2, Group A, B, C, D • Class II, Div 2 Groups F, G • Class III Hazardous Locations
CE (EMC)	European Union 89/336/EEC EMC Directive, compliant with: EN 61000-6-2; Industrial Immunity EN 61000-6-4; Industrial Emissions
CE (LVD)	EN 61131-2; Programmable Controllers
C-Tick	Australian Radiocommunications Act, compliant with: AS/NZS CISPR 11; Industrial Emissions
Marine	Products identified with the suffix M in the catalog number, are certified to the requirements of one or more marine societies.

⁽¹⁾ See the Product Certification link on <http://www.ab.com> for declarations of conformity, certificates, and other certification details.

Additional Resources

For additional information on the terminals, refer to these publications.

Resource	Description
PanelView Plus User Manual, publication 2711P-UM001	Provides an overview of the PanelView Plus and PanelView Plus CE terminals and gives information on how to install, operate, configure, and troubleshoot these devices.
Wiring and Grounding Applications for PanelView Plus devices Technical Data, publication 2711P-TD001	Provides additional information on wiring and grounding the PanelView Plus and PanelView Plus CE terminals.
PanelView Plus Compact Terminals User Manual, publication 2711PC-UM001	Provides an overview of the PanelView Plus Compact terminals and gives information on how to install, operate, configure, and troubleshoot these devices.

You can view or download publications and translated versions of the installation instructions at <http://literature.rockwellautomation.com>.

To order paper copies of technical documentation, contact your local Rockwell Automation distributor or sales representative.

Rockwell Automation Support

Rockwell Automation provides technical information on the Web to assist you in using its products. At <http://support.rockwellautomation.com>, you can find technical manuals, a knowledge base of FAQs, technical and application notes, sample code and links to software service packs, and a MySupport feature that you can customize to make the best use of these tools.

For an additional level of technical phone support for installation, configuration and troubleshooting, we offer TechConnect support programs. For more information, contact your local distributor or Rockwell Automation representative, or visit <http://support.rockwellautomation.com>.

Installation Assistance

If you experience a problem within the first 24 hours of installation, please review the information that's contained in this manual. You can also contact a special Customer Support number for initial help in getting your product up and running.

United States	1.440.646.3434 Monday – Friday, 8 a.m. – 5 p.m. EST
Outside United States	Please contact your local Rockwell Automation representative for any technical support issues.

New Product Satisfaction Return

Rockwell Automation tests all of its products to ensure that they are fully operational when shipped from the manufacturing facility. However, if your product is not functioning and needs to be returned, follow these procedures.

United States	Contact your distributor. You must provide a Customer Support case number (see phone number above to obtain one) to your distributor to complete the return process.
Outside United States	Please contact your local Rockwell Automation representative for the return procedure.

Allen-Bradley, Rockwell Automation, FactoryTalk View, PanelView, PanelView Plus, and TechConnect are trademarks of Rockwell Automation, Inc.

Trademarks not belonging to Rockwell Automation are property of their respective companies.

www.rockwellautomation.com

Power, Control and Information Solutions Headquarters

Americas: Rockwell Automation, 1201 South Second Street, Milwaukee, WI 53204-2496 USA, Tel: (1) 414.382.2000, Fax: (1) 414.382.4444

Europe/Middle East/Africa: Rockwell Automation, Vorstlaan/Boulevard du Souverain 36, 1170 Brussels, Belgium, Tel: (32) 2 663 0600, Fax: (32) 2 663 0640

Publication 2711P-IN001I-EN-P - November 2009

Supersedes Publication 2711P-IN001I-EN-P - March 2009

Copyright © 2009 Rockwell Automation, Inc. All rights reserved. Printed in the U.S.A.